

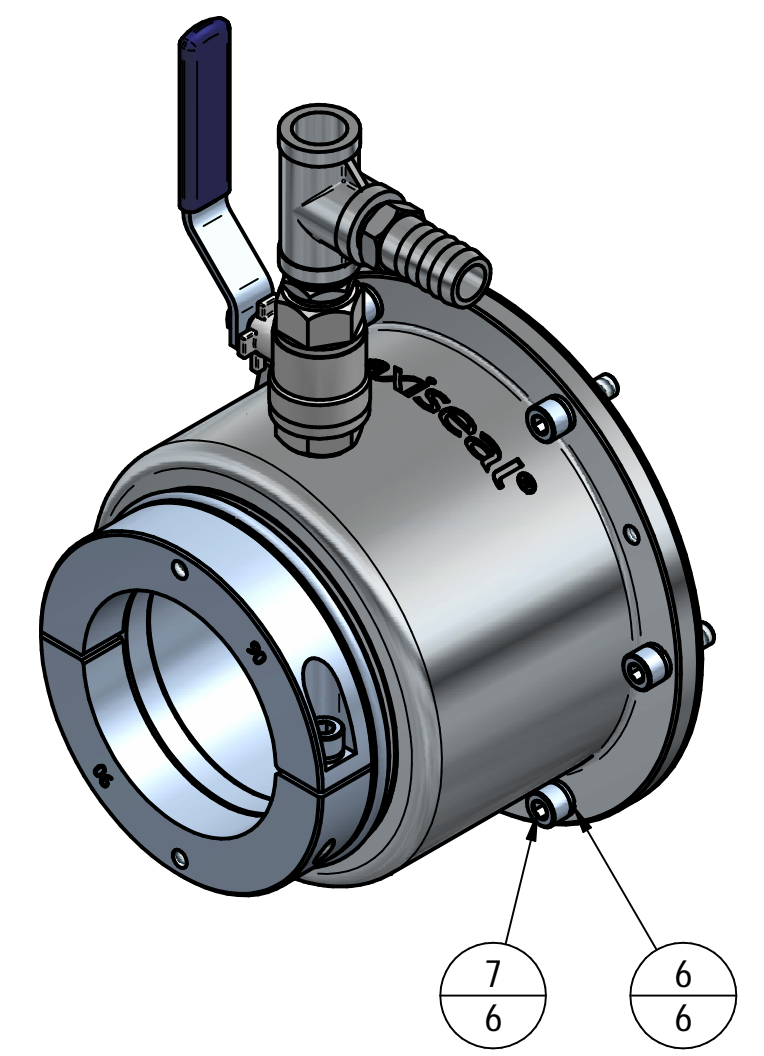

Rev	Description	Date
A	Mod Stat Seat & mat gasket, added O-Ring	16-8-2021

SECTION A-A

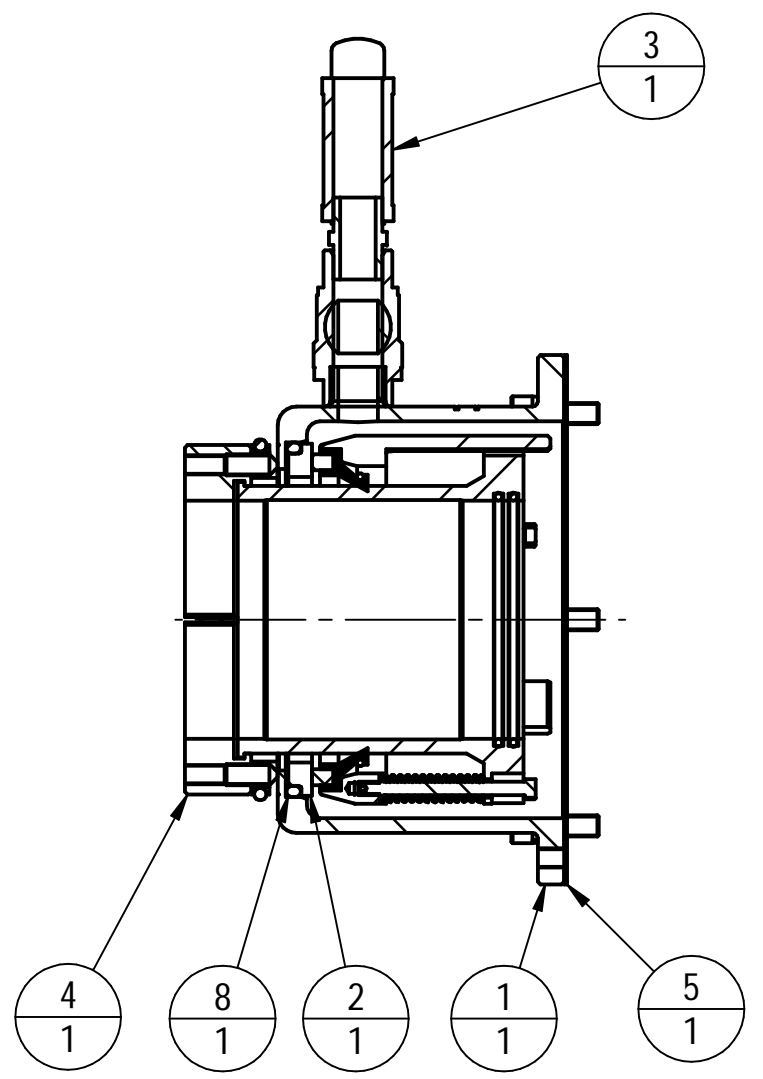
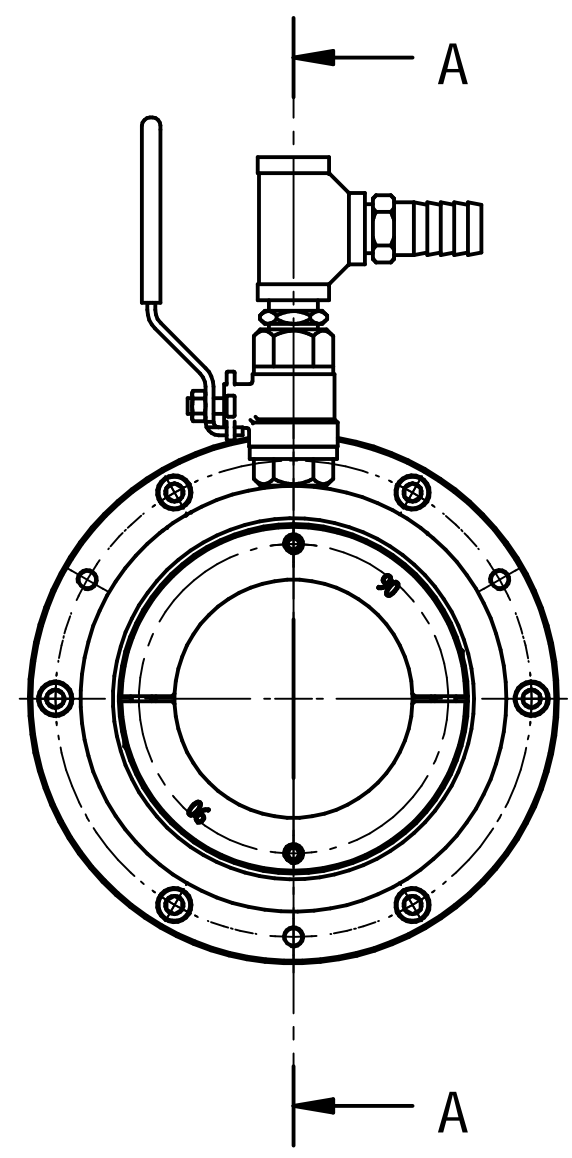

Item Nr	Drawing Nr	Product code	Title	Material	Qty.	Mass
1		611.1-090	Housing	Duplex 1.4462	1	3.474 kg
2		611.2-090	Stationary Seat	Stainless steel Alloy 2507 (1.4410)	1	0.275 kg
3		613-G0.5	Water supply 0.5"		1	0.586 kg
4		612-090	Inner sealing assembly		1	4.425 kg
5		614.1-090	Flange gasket	PTFE	1	0.028 kg
6	-	DIN7980_M8-A4	Spring lock washer	Stainless Steel, A4	6	0.007 kg
7		DIN912 M8x25-A4	Hexagon Socket Head Cap screw	Stainless Steel, 316 (1.4404)	6	0.104 kg
8		DIN3771 125x5	O-ring	NBR	1	0.009 kg

Date drawn: 29-1-2014	Not specified tolerances according to ISO2768	This is copyright of AMARTECH and this should not be used, reproduced or modified in any way without prior written permission. © All rights reserved
Date checked: 19-8-2021	Dimensions: mm	
Drawn: Danny	Product code: 610-090	
 Propulsion System Engineers +31(0)184616400 www.amartech.nl	Title: Axiseal	
	Drawing nr.: 610-090	
Order nr:		Rev.: A