

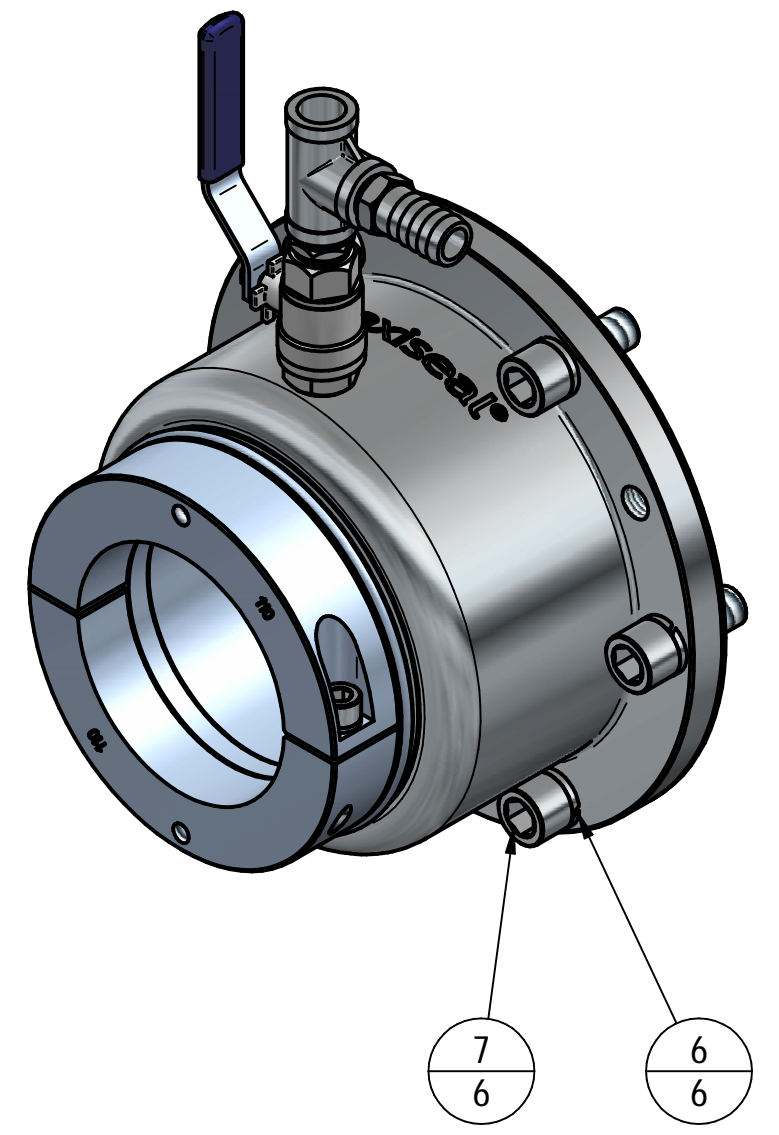

Rev	Description	Date
A	Mod Stat Seat & mat gasket, added O-Ring	16-8-2021

SECTION A-A

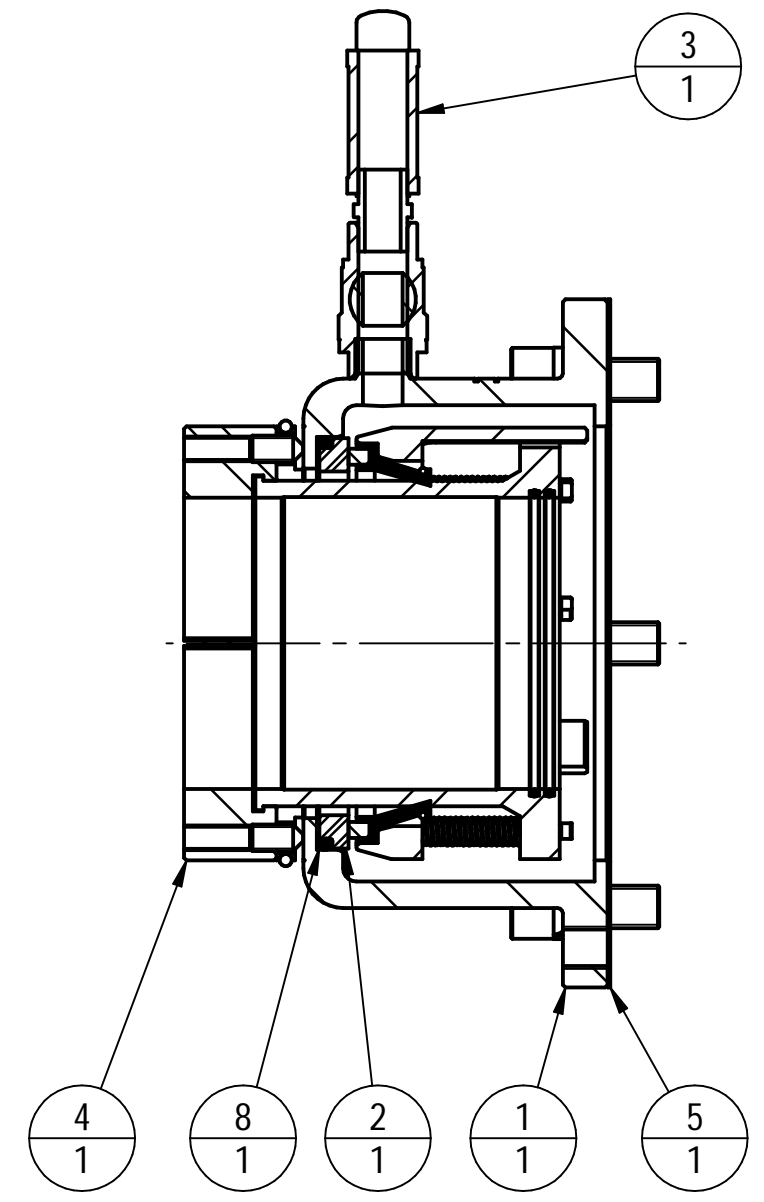
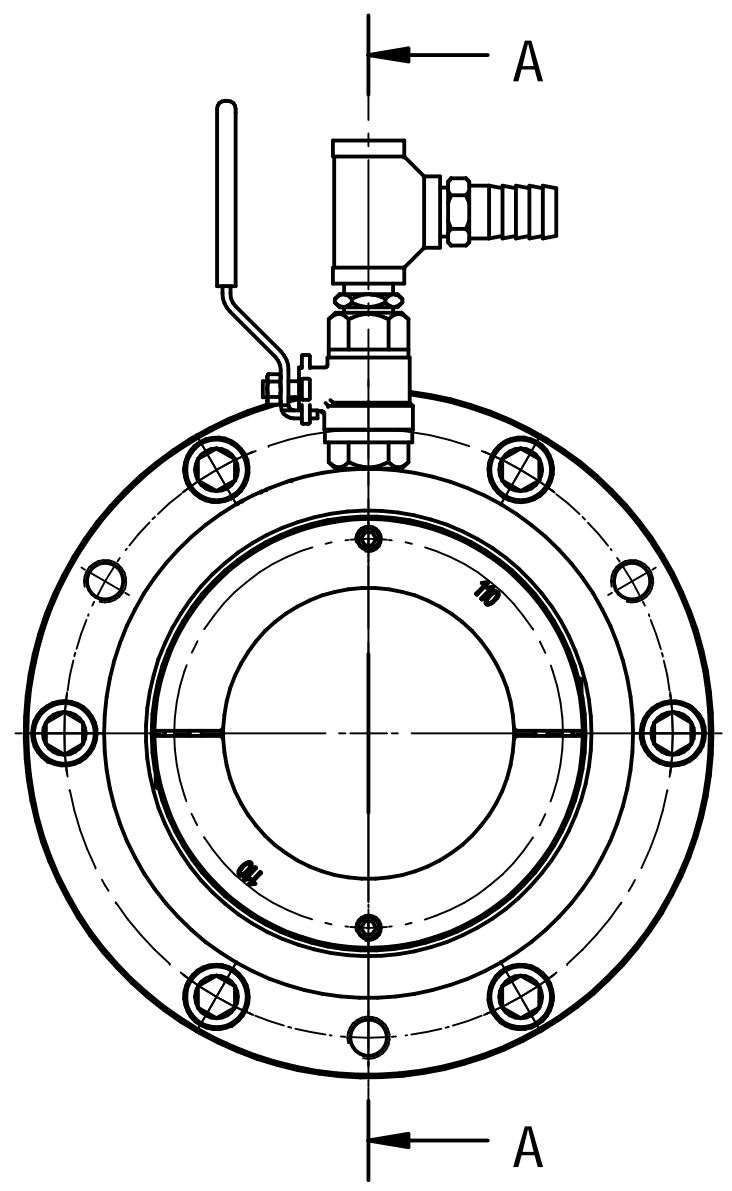

Item Nr	Drawing Nr	Product code	Title	Material	Qty.	Mass
1		611.1-110	Housing	Duplex 1.4462	1	8.900 kg
2		611.2-110	Stationary Seat	Stainless steel Alloy 2507 (1.4410)	1	0.413 kg
3		613-G0.5	Water supply 0.5"		1	0.586 kg
4		612-110	Inner sealing assembly		1	7.346 kg
5		614.1-110	Flange gasket	PTFE	1	0.065 kg
6		DIN7980_M16-A4	Spring lock washer	Stainless Steel, A4	6	0.043 kg
7		DIN912 M16x40-A4	Hexagon Socket Head Cap screw	Stainless Steel, A4	6	0.629 kg
8		DIN3771 145x5	O-ring	NBR	1	0.011 kg

Date drawn: 29-1-2014	Not specified tolerances according to ISO2768	This is copyright of AMARTECH and this should not be used, reproduced or modified in any way without prior written permission. © All rights reserved
Date checked: 19-8-2021	Dimensions: mm	
Drawn: Danny	Product code: 610-110	
 Propulsion System Engineers +31(0)184616400 www.amartech.nl	Title: Axiseal	
	Drawing nr.: 610-110	
Order nr:		Rev.: A